



Over 90 Years Of Quality Foodservice  
Products And Service

Job \_\_\_\_\_ Item No. \_\_\_\_\_

## GF-30 Gas Counter Top Fryer



Model GF-30

### DESCRIPTION

Wells GF-30 Gas counter top fryer is one of the most dependable, durable and easy-to-use fryers in the industry and comes with two side hanging, full-size fry baskets standard. The fry pot is made of stainless steel and features a front access drain valve and holds 30 Lbs. of oil.

### SPECIFICATIONS

**CONSTRUCTION** – features stainless steel top, front, sides, and fry pot. Adjustable 4" legs are standard. a 1/2" N.P.T. female gas connection is provided.

**GAS FIRED** – The GF-30 features 70,000 BTUH in Natural gas and 65,000 BTUH in LP gas for quick pre-heat and fast recovery. The high-performance, in-shot burner with copper plated kettle fins deliver even heat distribution and optimal heat transfer. Pre-heat time to 350° F is approximately 12 minutes. 4,900 BTUH is required to maintain 350° F. The GF-30 will produce 65 Lbs. of French fries per hour.

**CONTROLS** – The operator-controlled, snap action thermostat ranges from 200° F to 375° F and responds quickly to temperature adjustments, while an automatic pilot light is provided for easy ignition. A high-limit safety thermostat is provided standard.

### STANDARD FEATURES

- Stainless steel front, top & sides
- Stainless steel 30 Lb. fry pot with front access drain valve
- Two, full-size fry baskets
- 4-inch adjustable legs
- In-shot burner with 70,000 BTUH in Natural gas or 65,000 BTUH in LP gas
- Positive-off operator-adjustable thermostat
- Safety high-limit thermostat to prevent over heating
- 1/2" female N.P.T. rear gas connection
- 2-year limited parts & 2-year limited labor warranty

### OPTIONS & ACCESSORIES

- Full size fry basket
- Fry pot replacement
- 4-inch metal leg set of four

### CERTIFICATIONS



Sheet No. GF30-3/16



Wells Bloomfield • 10 Sunnen Dr. St. Louis, MO 63143 U.S.A.  
Phone : (314) 678-6314 • Fax (314) 781-5445  
www.wellsbloomfield.com • Printed in the U.S.A.

**NOTE:** Specifications are subject to change without notice and are not intended for installation purposes. See installation instructions prior to installing the unit.



Over 90 Years Of Quality Foodservice  
Products And Service

# GF-30 Gas Counter Top Fryer

MINIMUM CLEARANCE REQUIRED FROM UNIT TO THE NEAREST SURFACE			
BACK	SIDE	BOTTOM	FRONT
0	0	4	0
0	0	[10.1]	0

NOTE: Specifications are subject to change without notice

**NOTE:** Specifications are subject to change without notice and are not intended for installation purposes.

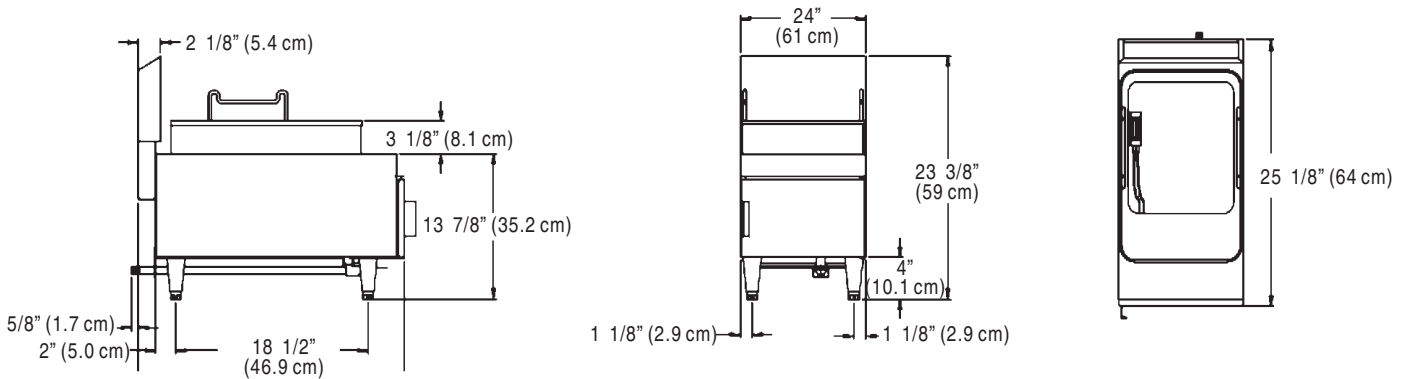

Model Number	W x D x H (w/legs) 610mm x 640mm x 590mm	BTUH Ratings		Weight (Shipping) 118 Lbs. 54 Kilos	Weight (Installed) 110 Lbs. 50 Kilos
		NG	LP		
GF-15	24" x 25-1/8" x 23-3/8"	70,000	65,000		

Due to periodic changes in designs, methods, procedures, policies and regulations, the specifications contained in this sheet are subject to change without notice. While Wells exercises good faith efforts to provide information that is accurate, we are not responsible for errors or omissions in information provided or conclusions reached as a result of using the specifications. By using the information provided, the user assumes all risks in connection with such use.



**Wells Bloomfield** · 10 Sunnen Dr. St. Louis, MO 63143 U.S.A.  
Phone : (314) 678-6314 · Fax (314) 781-5445  
www.wellsbloomfield.com · Printed in the U.S.A.

**NOTE:** Specifications are subject to change without notice and are not intended for installation purposes. See installation instructions prior to installing the unit.